

Aackon

created with ingenuity built on integrity.



OWNER'S MANUAL

Economy Rack's

ER-1520-1420

ER-1550-1200

ER-1880-1600

ER-1880-1400

ER-2025-1820

This manual is provided in conjunction with instructions of assembly and spare part lists to fully inform the relevant personnel safety and in usage and maintenance.

Contents

Index	1
Info. Description	2
Features & Specification	2
Compliance label	3
Safety Labels	4
ABA (Bolt assembly)	5
Bolt torque	6
RTAA (assembly)	7
RTAA (procedures)	8
Drawings components	9 - 10
Assembly	11 - 16
Wheels + Part Nr	17
Pole + Part Nr	18
Load safely	19
How not to load	20
Warranty	21
Document container.....	21
Certificate	22

Description

Economy Rack – Aframe compact intermediate in common size useases with versitly for factory, trucking, jo site material handling, glass, stone, cladding sheets.

Featur& Specification:

ER-1550-1200	Tare 146 kgs
ER-1520-1420	Tare 160 kgs
ER-1880-1400	Tare 173 kgs
ER-1880-1600	Tare 180 kgs
ER-2025-1820	Tare 197 kgs

- Eyelets 2500 kgs. W.L.L
- Tug Wheeling 2500 kgs. W.L.L
- Fork side 3000 kgs. W.L.L
- Stationary 3500 kgs. W.L.L
- Load bay EPDM black rubberized
- Quick pin release H/duty wheels
- Forkable 4 sides
- Safety work height peg poles strapping
- Longitude mid tie rail
- Document rainproof container
- Poles load tie bars P24



ER-1550-1200 Tare 146kgs
ER-1520-1420 Tare 160 kgs
ER-1880-1400 Tare 173 kgs
ER-1880-1600 Tare 180 kgs
ER-2025-1820 Tare 197 kgs

Economy Rack

Transporting A-frame

Fork Side	3000 kgs	W.L.L
Fork End <small>Slipper</small>	2000 kgs	W.L.L
Eyelets	2500 kgs	W.L.L
Crane Slipper	3000 kgs	W.L.L
Tug Wheeling	2500 kgs	W.L.L
Stationary	3500 kgs	W.L.L

LIABILITY

- NO LIABILITY WILL BE CLAIMED AGAINST THE MANUFACTURE OR IT'S DISTRIBUTORS FOR DAMAGE(S) OR ACCIDENT(S).
- USER & BUYER MUST READ, UNDERSTAND & COMPLY WITH ALL LABELS + MANUALS.

INSPECTION

FRAME	<input type="checkbox"/>	LOAD BARS	<input type="checkbox"/>	PINS	<input type="checkbox"/>
WELDS	<input type="checkbox"/>	STRAPS	<input type="checkbox"/>	RUBBER	<input type="checkbox"/>
BOLTS	<input type="checkbox"/>	SHACKLES	<input type="checkbox"/>	CAPS	<input type="checkbox"/>
EYELETS	<input type="checkbox"/>	WHEELS	<input type="checkbox"/>	LABELS	<input type="checkbox"/>

SIGNED : D

ATE :





WARNING

- READ & UNDERSTAND THE MANUAL & ALL LABELS BEFORE OPERATING.
- BRAKE MUST BE ON WHEN UN/LOADING.
- UNBALANCE LOAD MUST BE LIFTED FROM BASE ONLY!!
- DO NOT PASS UNDER A-FRAME.

CAUTION

- LOAD + FRAME NOT TO EXCEED W.L.L.
- LOAD TO BE SECURED BEFORE MOVING.
- MAXIMUM LOAD HEIGHT NOT TO EXCEED LOAD BAY HEIGHT BY 30%
- MAXIMUM LOAD LENGTH NOT TO EXCEED LOAD BAY LENGTH BY 25% ON ENDS.

DANGER

- DAMAGED FRAME, LOAD BAR, STRAPS ETC ARE NOT TO BE USED.
- ACCIDENT MAY OCCUR IF LOAD IS NOT SECURED BEFORE MOVING.
- AVOID ACCIDENT BY LIFTING FRAME + LOAD PARALLEL & EVEN AT ALL TIMES !!

MAINTENANCE

- ALL LABELS TO BE CLEAN & VISIBLE.
- CHASSIS, BOLTS, LOAD BARS, STRAPS ETC. MUST BE INSPECTED BEFORE USE, FOR LOOSE, WARE OR DAMAGE.
- CHASSIS AND RUBBER CLEANED WEEKLY.

CRANE - CAUTION

- DO NOT CRANE SLING THROUGH FORK POCKET.
- FOR HEAVY OR UNBALANCED LOAD USE CRANE LIFTING SLIPPER AT FORK POCKET.
- SITE CRANING LOAD MUST BE WITHIN A-FRAME HEIGHT & LENGTH DIMENSION.

FORKLIFT - CAUTION

- FORKTRUCK TYNES TO BE INSERTED TO MAXIMUM DEPTH WHEN LIFTING.
- FORKTRUCK NOT TO PROJECT AGAINST RETENTION POST WHEN LIFTING OR MOVING.

WHEELS - CAUTION

- INSPECT WHEELS + CARRIAGE BEFORE USE.
- ENSURE PINS, CLIPS, NUT, ETC AND WHEELS ARE SECURED AND ARE NOT DAMAGED.
- ACCIDENT MAY OCCUR IF WHEEL CARRIAGE IS NOT SECURED OR IF DAMAGED.

SAFETY - CAUTION

- SAFETY ATTIRE TO BE WORN.
- A-FRAME TO BE LEVEL FOR UN/LOADING.
- NOT TO BE USED IN WET OR WINDY CONDITIONS.
- ONLY TRAINED & COMPETENT PERSONNEL TO USE.

AACKEN BOLT ASSEMBLY of rack trolley aframe

Zinc bolts - require annually maintenance pass
(higher cost factor , of year's ahead)

Dry bolts - nuts thread are subject to thread
clenching during ' screw up

Lubrication or thread lock (blue tube liquid) will extend
bolt life if applied.

Galvanize bolts - maintenance at 5 years,
visual pass at 12 months (lower maintenance cost year's ahead)

All bolts to be pre assembled semi loose then with a
3 stages torque up 80% ,90% final 100%

Using blue liquid thread lock tight will act as lubricant prolonging
the galvanize bolt, sealing out acid rain or salt coastal moisture.
Once the blue thread lock tight has semi set bolt and nut thus
never comes lose with usages and temperature changes.

Never use blue lock tight on hand screw up, as will pre - set
quick with time temperature, use only on tight screw up or
torque screw up.

Knowledge (nut torque P6)

Read the torque carefully, as torque are different of same
size, nut TQ is not the same as bolt TQ
Wet TQ not the same as dry TQ

Nut's TorqueBolt !!

"Beware " Dry or Wet torque are different (wet is lower TQ)
Also " Nut TQ" is different from " bolt TQ" of same size
(higher TQ)

Value are hexagon head bolt - nut grade 8.8 or 9.8

Diameter	Wrench	Dry torque	Wet torque	Wet TQ	Red or green
M5 nut	8mm	6Nm	5.3Nm		Lock tig t
M6 nut	10mm	10Nm	9Nm	Use only	
M8 nut	13mm2	5Nm	22Nm	blue lock	Do Not use
M10 nut	16mm	50Nm	45Nm	tig	on bolts
M12 nut	18mm	85Nm	76Nm		
M14 nut	21mm	140Nm	125Nm		

- * M12 bolt wet torque 84Nm (as M12 Nut not possible to torque of confine space)
- * M14 bolt wet torque 130Nm (as M14 Nut not possible to torque of confine space)

Aacken bolts / Nuts comply's to AS / NZS 1252: 1996

Aacken bolts are supply in kits form, usually bolt shaft with threaded end. Two flat washer, one spring and one nut, which consist the larger flat fitted to thinner metal component side and smaller flat washer under spring washer, then nut on spring washer.

ATTENTION - INFORMATION

Aacken anchor bolts of base to bottom of 'A'

1. Should always be pointing upward,
(head under base structure with nut washer set on top of 'A' base footing)
2. The bolt thread must project 5mm past nut, (ANZ-standard)
3. Other bolts set may point downward that are not subject ti direct hoist lifting, eg. rail bars and top eyelets beam bar
4. **Carefully note** - that eyelet beam bar is under top 'A' steel structural. Not bolt anchor pulling.

ARRIVAL of Shipment

- On arrival check package if damage
- Note date and time of receivable packages
- If damage must take photo or photos
- Inform the freight forwarder
- Email the supplier with support evidence
- * Note ! damage claim can only be at time date of delivery of receive goods.

RTAA RACK TROLLEY AFRAME ASSEMBLE

Read carefully follow sketches Pg 9 > Pg 16

- Man or men must wear safety clothing (steel toe boots etc.)
- Read and understand "ABA data sheet, of Aacken bolts assembly as on P5 and P6 this manual
- Assemble in non traffic area with no distraction
- Good light visuals, with no toxic fumes, or loud noise
- Ensure shipping package are stable, not to fall over or slide when unpacking
- Do not hand lift heavy components by one self
- Numbers of men, or hoisting lifting equipment must be used with safety hoisting equipment certified and validated
- Electric power cable tools not be used !
- Use only battery power tools and fastening tools set
- Use the correct spanner/ wrench size to bolt/nut head sizes
- Torque wrench to use on lifting - hoisting anchor bolts

Procedures

1. Unwrapped rack - base, mount low and level for assemble wheels may be fitted if desire.
2. Ensure wheel are 2 ridge type fitted at one end of base frame and caster swivel tow-tug end with bolts type or pins type lock fixture type's, or other auto gate lock type, wheels are to be brake lock or chock not to move during assemble
3. 'A's may look the same, but are different, End 'A's (one with safety label or handle are end 'A's are fitted last)
4. Fit central 'A' first to base chassie (mid central position)
5. Centre 'A's is semi fix first with achor bolt thread pointing upward, bolts hand screw only, until all parts are together
6. Install the other 'A's adjucent to center A with 1 flat washer at head of bolt, second flat and spring washer under nut. Then end A's with handle
7. Fit central angle bar with document tube pounch to ends 'A's with warning and swivel wheels end, screw pointing downwards bolts by hand only.
8. Fit low Ø16 tube tie bar at 1st level (hand screw only)
bolts downwards
9. Beam bar (eyelets) 'MUST' go under top 'A's steel cross bar (eyeless beam must NOT sit on of 'A's.) bolts downwards
10. After all components are all semi bolted in place.

Eyelets beam bar are faster after base bolts are secure and follow by mid central stable bar or tie rail bar with also document pounch container.

Aacken recommend method of wet blue lock tight, prior to bolt / nut tight torque it prolong the life and low future maintenace cost.

Do not apply blue tight on hand screw up, as it go'es off. Take off nut apply blue lock tight and torque up

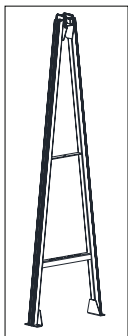

x2 Outer 'A'

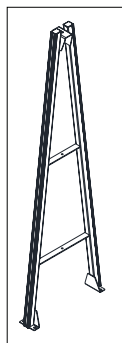

x2 Central A's

x2 Inner A's
identical

1 end "A" with lable fitted
to caster wheel, frame base
end and opposite end 'A'
fitter to rear of frame chassie
that has ridge wheels

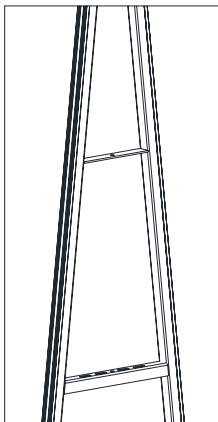

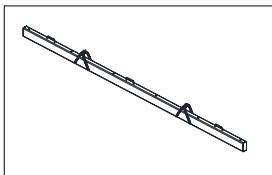

Top, Eyelet beam bar
with 3 strap tie rails.

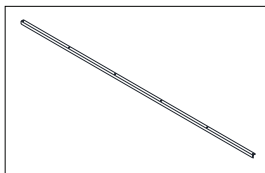

(A's longitude)
Cross bar's
Short mid
Long bottom

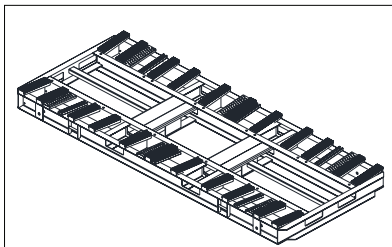

Chassis base

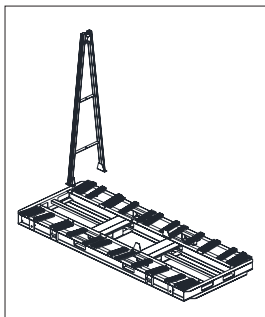

Fit Central position

Fit 4 wheels or mount base
on workshop rail stand

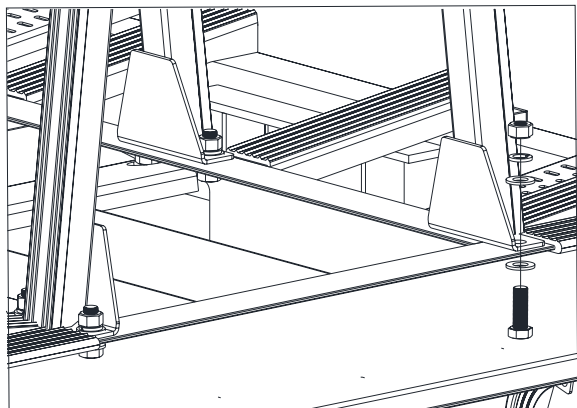
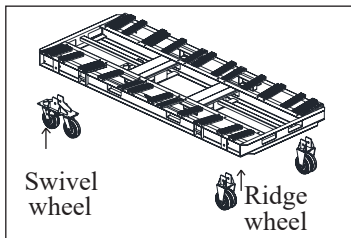

M14 bolt x 40 mm attach upwards

Fit 2 central A's, then 2 inner A's

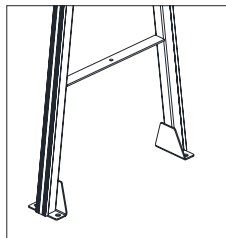
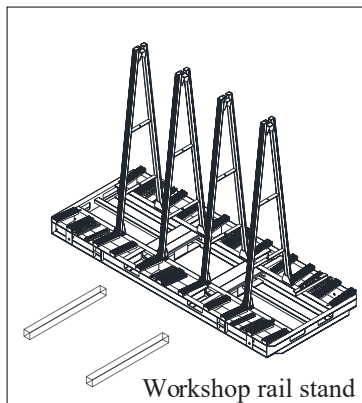

A's base feet flange

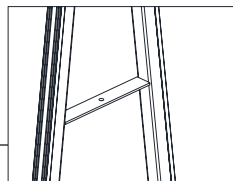
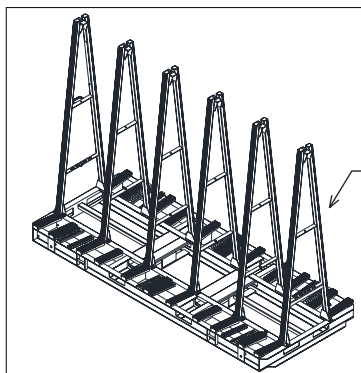

Fit 2 A's

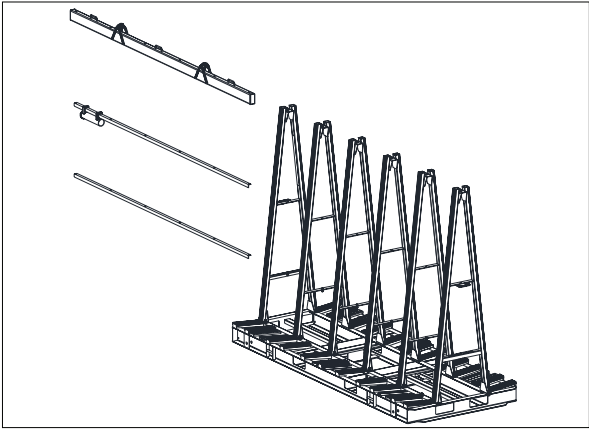

Add document container
to Cross bar

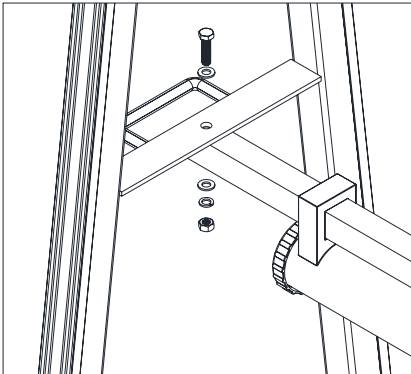

Fit M14 long bolts downwards

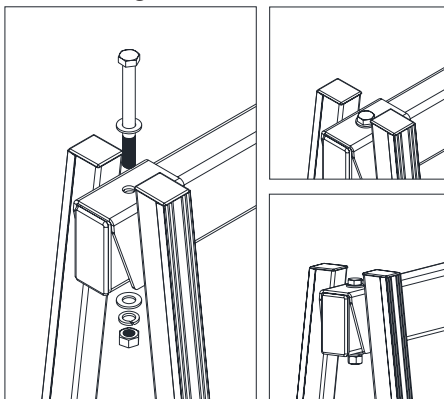

Add eyelet cross bar, as shown in diagram
fit under "A" top tube bridge

Take off nut apply
Blue thread lock tight
if desired

Galvanize M12 nut 8.8 wet
torque in 3 stages 80%, 90%, 100%
Nut torque 76 Nm@ 100%

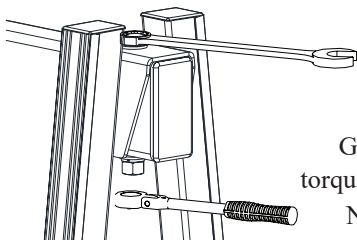

**** = model length of frame

Pos	Part No.	Description	Qty
1	ER****-B	Base chassis	01
2	ER-150N-R	Swivel dual brake wheel	01
3	ER-150N-SDB	Ridge fixed wheel	01
4	ER****-A17	Inner A's	04
5	ER****-A17E	End A's	02
7	ER****-AB	Central angle bar	01
8	ER-DC	Document container	01
9	ER****-TB	Top beam bar	01
11	ER****-SL	Compliance steel label	01
12	ER****-CL	Compliance label	02
13	ER****-BB	Base set bolt M14 x 40	12
14	ER****-AB	Central 'A' bolt M8 x 35	06
15	ER****-TBB	Top beam bar bolt M12 x 120	06
16	BTSR-43B	EPDM base slot rubber	12
17	ER-BFC	Base support footing cap	12
18	TSR-43B	'A's T-slot rubber	12
19	ER-ATC	'A's plastic cap 40 x 20	04

QtyB	oltF	lat washer	QtyS	pring washer	Nut
12	M14x 40	M14x 29x 2.52	4M	14	M14
6M	12x 120	M12x 27x 2.51	2M	12	M12
5M	8x 35	M8x 15x 21	2M	8M	8
1M	8x 25				

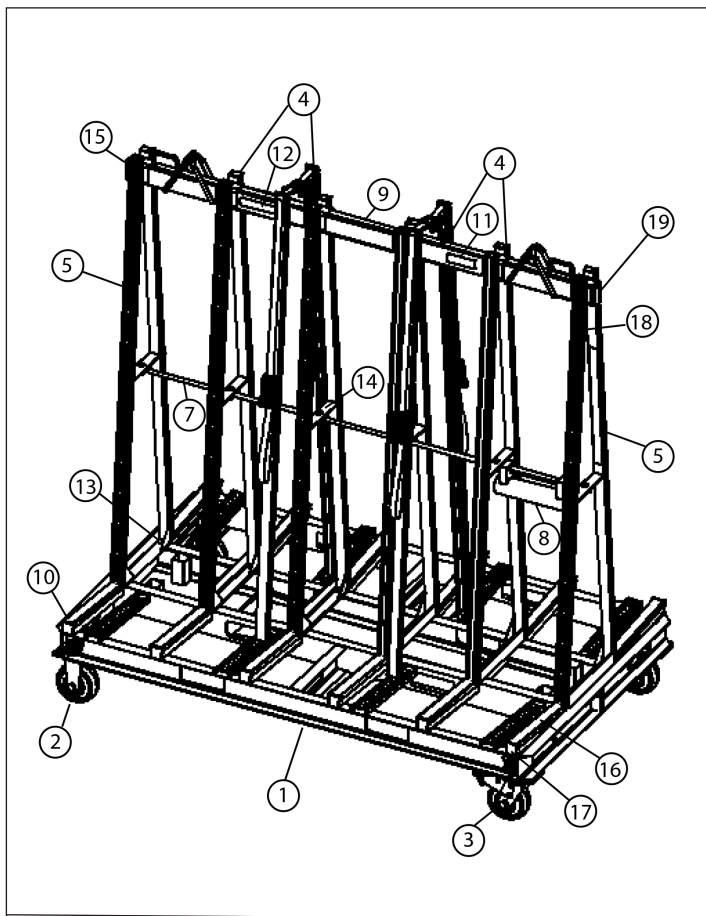

Wheels & lock pins

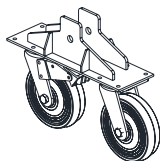

Qty: 2

Swivel dual brake
 Ø200 (8") wheel
 H/duty white nylon
 1300 kgs
 1700 kgs level concrete

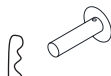

GM-PWB/140

Pin wheel bracket
 140 mm x 9.8 mm
 Zinc
 Set 4



Qty: 2

Ridge-Fixed
 Ø200 (8") wheel
 Big bearing white nylon
 950 kgs
 1300 kgs level

Safety retention pole

set of four

DOME CAD BBC-30W

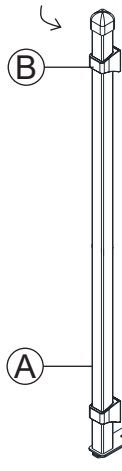

Part Nr	Description
(A) T/O-	- Two in one pole
(B) TSPPC/G	- Silde protection pole cushion

Stainless slide feet

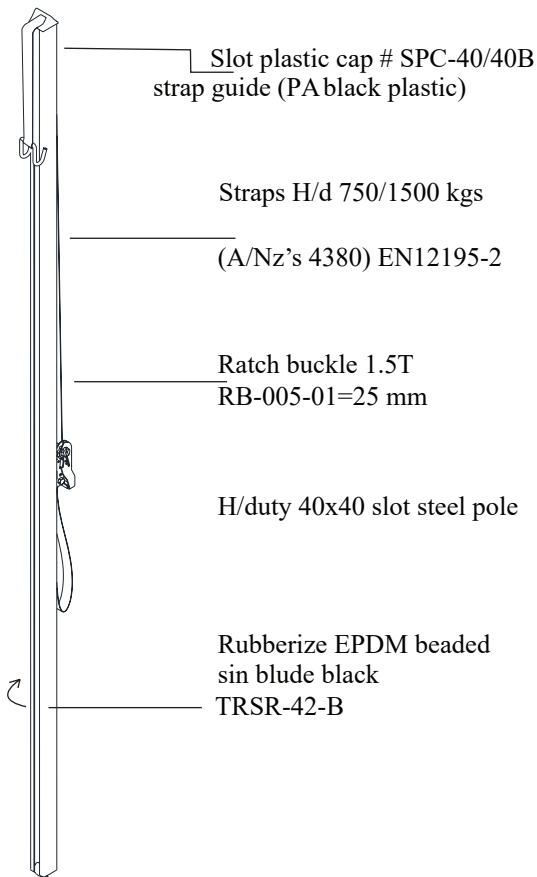

**LOAD
SAFETY**

- S1. Must be stack central
- S2. Must be stack to both sides of rack
“A”s equally
- S3. To be same size or approximately
same weight factor

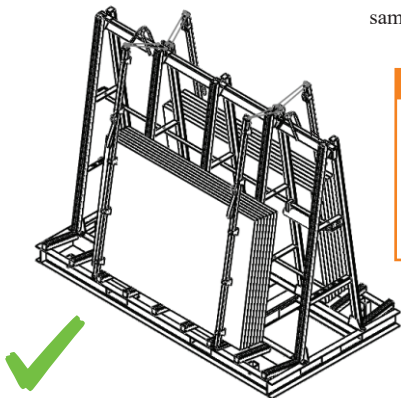
**⚠ WARNING ⚠**

Materials load for Forklift,
hoisting, wheeling or storage mode

- W1. To be pole brace or
- W2. To be pole strap secure
- W3. Or to be ratchet strap

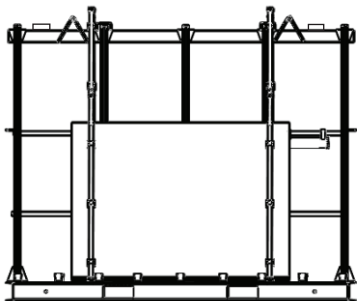

Job-site craning material, to be shrink wrapped

Examples Not to load

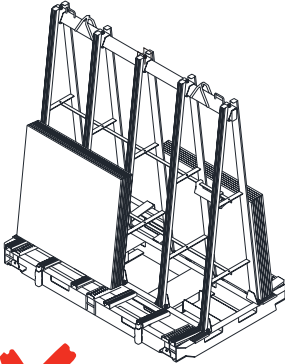

Never stack like this !

This may lead to injury or accident
Forktruck or pallet jack usage

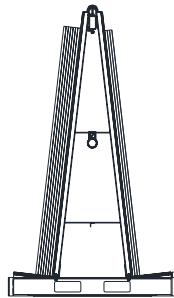
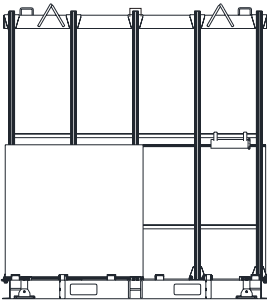

No, Pole brace or strapping will invite
“sooner than later” accident

Forklifting.

Always make sure your forks are fully inserted into the A-Frame before lifting, and this will ensure a proper and secure lift.

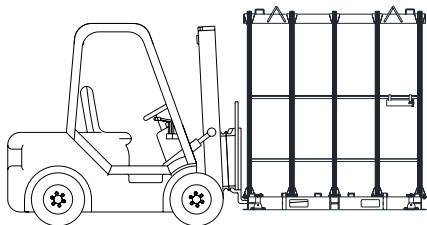

Tilt back
to 92°
for travel

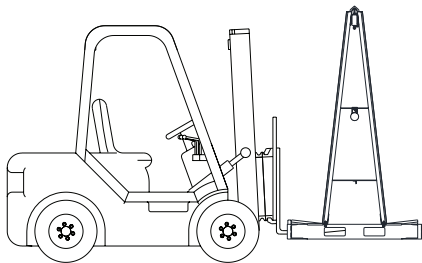

Tilt back
to 91°
to travel

THE CORRECT WAY OF REMOVING THE CASTERS:

Make sure the load is fully secured before removing the casters. Lift the A-Frame off the ground, high enough for you to have proper access to the casters. With one hand holding the caster, use your other hand to pull out the pin. This will release the caster from the A-Frame.

WARRANTY:

This product is warranted for twelve months from date of purchase to be free of manufacturing defects in material and workmanship. This warranty does not cover transporting and handling on or off sites, nor does cover normal wear of parts or damage resulting from negligent use or misuse of the product, use or application contrary to installation instructions, or disassembly, repair or alteration by any person prior to authorization from a factory representative. Aacken or its agents are not liable for freight/handling or loss of production cost. Purchase must notify the agent prior to use if the new A-Frame has been damaged or components are missing.

DOCUMENT CONTAINER:

Read Certificate, compliance labels, JSA, Manuals (prior to assembly ABA. RTAA).

Job Safety Analysis (part 1)

Procedure(s) for Aframe Trolley

1. Read compliance plate on frame before using.
2. Function of the 'Trolley Rack Aframes' should only be managed by Personnel experienced in their use and that they (the operator) be advised of any potential hazard(s) associated with its use.
3. Recognized potential hazard(s):
 - A/.Crushing** - (Risk Assessment Low)-Remote probability of crush injury to Bodily area of operator(s),of fatal consequences, subject to loss of load.
 - Crushing** - (Risk Assessment Low)-Occasional probability of crush injury to feet area of operator(s),of negligible consequences, subject to entrapment of feet under casters wheels.
 - B/.Cuts, Stabs, Puncture** - (Risk Assessment-Low)- Remote probability of cuts/stabs/punctures to bodily area of operator(s) of marginal consequence, subject to loss of load.
4. Function of the 'Trolley Rack Aframes', Buggy, Trolley type should only be done so wearing relevant Personal Protective Equipment - e.g. Steel toe Boots, Hand Protection Gloves, other if required Eye Goggles, Wrist Gauntlets, Hard Hat and Leather Apron,etc.
5. Function of the'Trolley Rack Aframes',Buggy Trolley type should only be done so with total and full concentration and free from distraction(s) from outside factors (e.g. no mobile phone).
6. Aframe- rack with heavy load wheeling to be tow-tug with elect-tug, or at ground ramps, or unlevelled, ground surfaces

Attention: Note!

Prior to construction Job- Site (obtain in writing if eyelets are acceptable for craning) as some countries / State laws and Job-Site prohibit a frame with eyelets to be used.

- Keep maintenance records to ensure safety checks are carried out.
- Check and tighten the nut and bolts on frequent basis
- Always keep the product clean and away from grease or other foreign substances as they may cause the product to have an incorrect operation.
- Confirm all the welded joints are free from any defect, corrosion or damage, such as rust, separation, crack and so forth on a frequent basis.
- Store in a dry and cool place.

Job Safety Analysis (part 2)

SAFETY REQUIREMENTS WHEN LIFTING / MOVING LOAD

- It is strongly advised that correct 'Personal Protective Equipment to be worn when operating.
- The operator is advised to warn other personal in the near vicinity to keep clear when any load is being lifted or moved.
- Loading or unloading frame to be on level surface.
- Load not to be loaded or unloaded in windy or rainy conditions.
- Load to be secured before lifting frame with load or moving.
- Site craning load must be lower eyelets height and overhang length max 25%.
- Shrink-wrap or load netting must be used for site craning.
- Load material height not to exceed 30% of load bay height. (Storage)
- Load not to project 35% pass load bay length. (Storage, safety barrier must be used)
- Glass less than 6 mm must not exceed 300mm pass frame dimensions when 500 mm less in height.
- Load weight not to exceed W.L.L.
- Load cargo straps or load locking bars system must be used.
- Load cargo strap must be used outside load bay size dimensions.
- Top eyelets use only if load is secured, balance within eyelets W.L.L.
- Lifting frame, from fork pockets or eyelets should only be for short periods of time. <10 mins. Do not rush lifts. Have a plan with safety before execution.
- For excess or unbalance load use crane lifting slipper.
- Single sided models do not crane or forklift Buggy A-Frame with load.
- When moving a load, the operator(s) is advised to keep their feet and legs clear of the suspended material. The load must be steadied and controlled at arms length.
- Any load must be moved as near to floor level as is practical unless obstructions make it unsafe or impractical to do so.
- Forklift within A-Frame fork pocket, with Forktruck carriage against A-frame, except trucking roll on roll off GTR series
- Do not lift loaded space A-frame in a counter lever manner with Forktruck (accident or damage will occur!) use long tynes or slipper's
- Frames with load in factory or site not to move more than 2kph with retaining peg-cam brace lock in position, or slide retention post, if equip, otherwise ratchet - strapping to be used.

www.Aacken.com
team@Aacken.com